

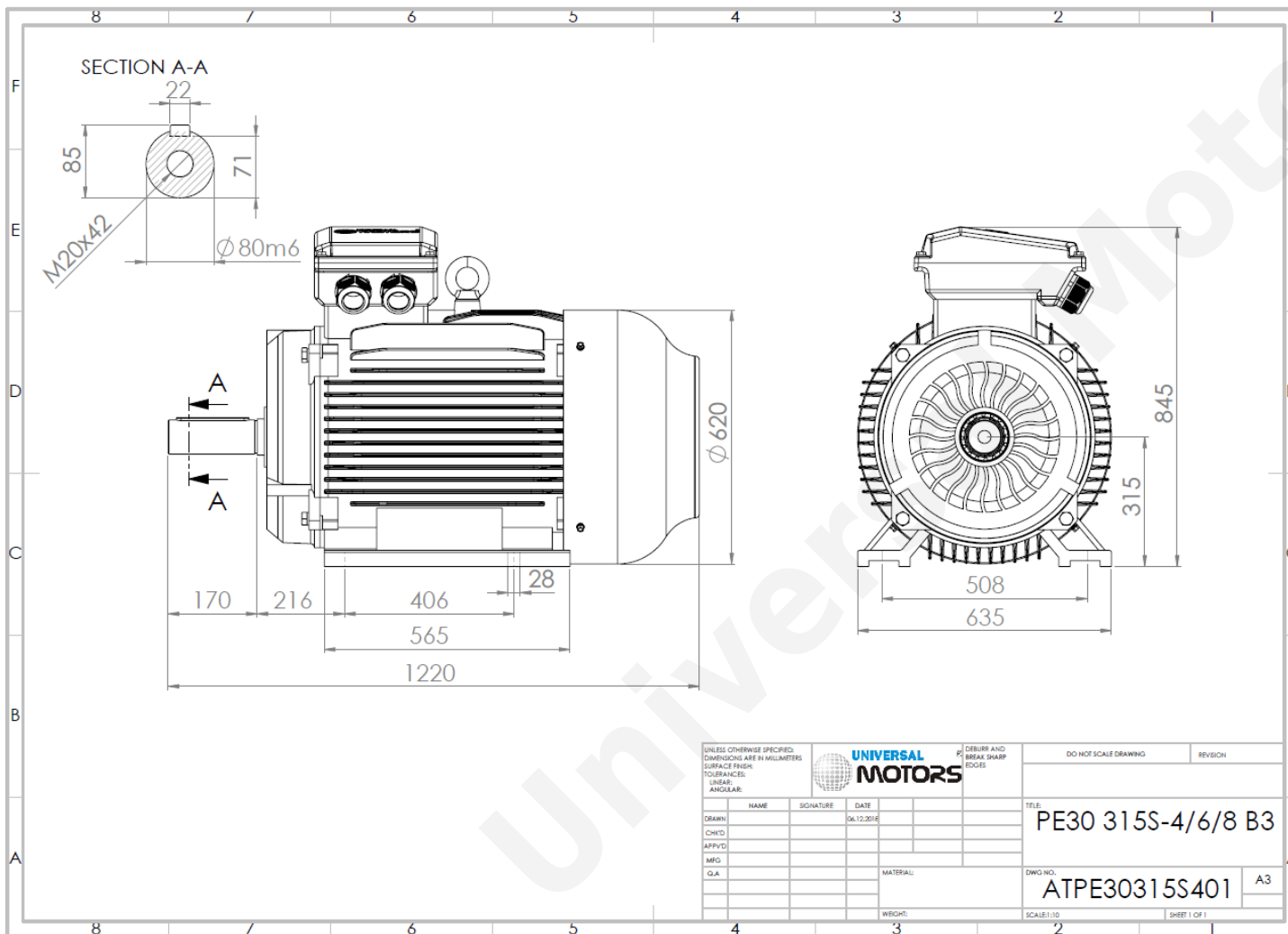

# TECHNICAL DATA

Three Phase Electric Motors - Cast Iron Frame  
 PE30 315 S 4 IE3  
 110 kW / 150 Cv  
 1485 RPM



Motor type:	PE30 315 S 4 IE3
Output:	110 kW / 150 Cv
Speed (min <sup>-1</sup> ):	1485 RPM
Frequency:	50 Hz
Voltage:	400 V
Current:	187 A
Power factor (Cos $\phi$ ):	0.89
Poles:	4
Insulation class:	F
Temperature rise Class:	B
Efficiency 50%:	94.7 %
Efficiency 75%:	95.4 %
Efficiency 100%:	95.5 %
Torque:	707 N.m
Tstarting/Tnominal:	2.0
Istarting/Inominal:	7.0
Tmaximum/Tnominal:	2.2
Noise:	77 Db(A)
Weight:	922 Kg
Bearing DE:	NU 319
Bearing NDE:	6319 C3

Regime - S1

Altitude - 1000m

Environment Temperature - 40°C

## CONTACTS:

UNIVERSAL MOTORS Tel: +351 252 299 080  
 Rua de São Brás, 745 Fax: +351 252 299 089  
 4480-782 VILA DO CONDE Mail: [geral@universalmotors.pt](mailto:geral@universalmotors.pt)

\* References applied only in the UK